



Product Catalogue

產品目錄

Model 型號: U76 series

代表型號的用途: 攪拌器 / 壓碎機 / 多用途食物處理器 / 及各種家庭電器等

Typical Application: Blender, Can Crusher, Food Processor and many other Household Electric Appliances.

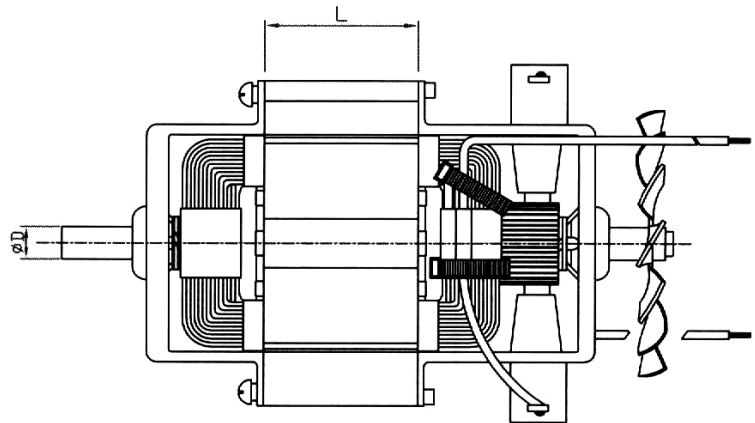
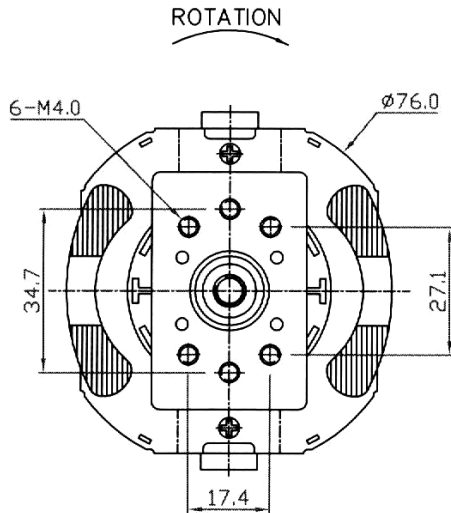

L = 25mm ~ 40mm D = 8mm

Output Condition: Lead-wire, Terminal, Multi-speeds, Custom made Shaft

MODEL	VOLTAGE		NO LOAD		AT MAXIMUM EFFICIENCY					STALL		
	OPERATION RANGE	NOMINAL (CONSTANT)	SPEED	CURRENT	SPEED	CURRENT	TORQUE		OUTPUT	TORQUE		CURRENT
			r/min	A	r/min	A	mN.m	g.cm	W	mN.m	g.cm	A
U7625-120	100V ~ 120V 50Hz	110V / 60Hz	17000	1.13	7800	2.57	137	1400	260	310	3200	4.46
U7628-230	220 ~ 240V 50Hz	230V / 50Hz	18000	0.40	8400	1.36	168	1700	92	320	3300	2.51
U7640 - 230	220 ~ 240V 50Hz	230V / 50Hz	16000	0.45	8200	1.35	174	1800	100	330	3400	2.04

U7625-120 230V / 50Hz

